

Gz Turbine Flowmeters

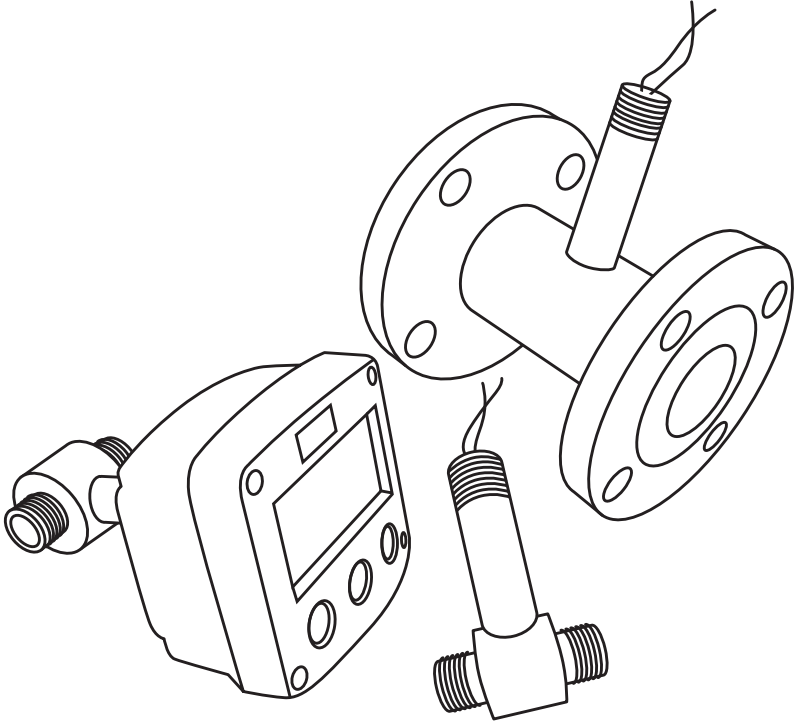

For Gas Flow Measurement



This Manual provides information and guidance for the installation, operation and maintenance of Gz Turbine Flowmeters.

Specification

Accuracy + / - 2 % of reading over Flow Range

Repeatability + / - 0.15 % of reading

Flow Range

Model	m ³ /h
Gz 13	1 – 8
Gz 16	2 – 16
Gz 19	4 – 32
Gz 25	7 – 56
Gz 40	14 – 112
Gz 50	26 – 208
Gz 80	42 – 336
Gz 100	86 – 688

Operating Temperature - 50 to + 160°C

Maximum Pressure Ranges from 20 to 250 bar (ref. to Catalogue)

Pressure Drop 12 mbar at Maximum Flow

Materials of Construction All 316 Stainless Steel with ANC1A Rotor

Bearings Ball Race / Hybrid Ceramic

Pick Up The Gz variable reluctance sensor is hermetically sealed for resistance to moisture and can withstand repeated thermocycling.

The magnet is resistant to demagnetization.

Output is a low level signal that ranges from 10 mV to 1 V peak to peak.

A screened twin core signal cable should be used for connection to the Pick Up.

Principle of Operation

The Gz range of Turbine Flowmeters meet the demand of most gas measurement applications.

They basically consist of three component assemblies, fitted inside a stainless steel body (locked with retaining rings), which has a Pick Up (variable reluctance sensor) fitted and come in a range of threaded and flanged styles.

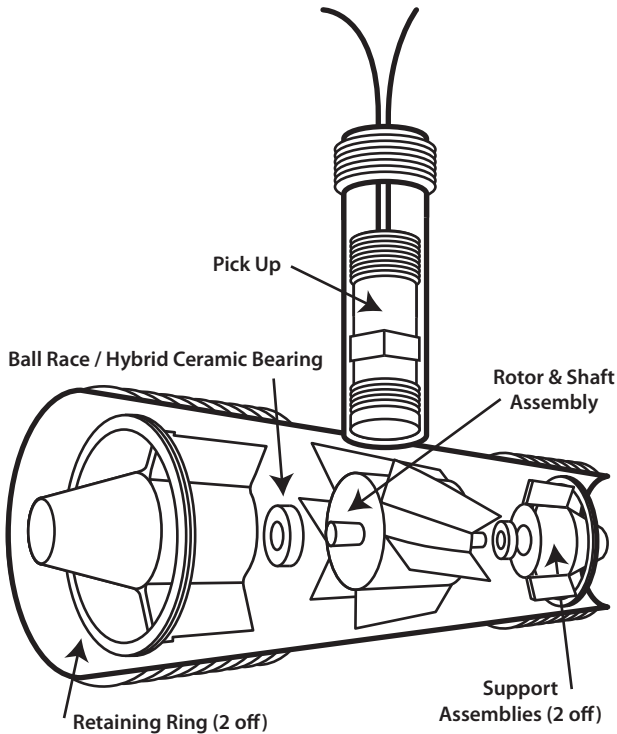

The Rotor and shaft assembly (1 off) which is mounted in ball race bearings, fitted inside Support assemblies (2 off) is turned by the kinetic energy of the flowing gas at an angular velocity, which in the linear range of the Flowmeter is proportional to the mean axial velocity of the gas.

The Rotor blades sweep out the full bore of the Flowmeter except for a small tip clearance space. As the blade tips pass the magnetic Pick Up (through the housing wall) they initiate a pulse. Flow rate is determined by the frequency of the pulses and Totalised Flow is obtained by summation of the pulsing electrical signal.

Installation

Carry out a visual inspection of the Gz turbine upon receipt, checking for indications of any possible transit damage.

Inspect all packing material carefully for associated components which may have been packed with the shipment.

The stem of the Gz Turbine is marked with a direction arrow to indicate the calibrated direction of flow through the Flowmeter.

Ensure that the Flowmeter is installed in the pipework in the correct orientation to obtain the best reliable operation.

In order to achieve the best electrical signal output from the Flowmeter install well away from current carrying cables, nearby motors and transformers.

The Gz Turbine Flowmeter may be installed horizontally or vertically.

It is good practice to install the Flowmeter with a minimum straight run of 10 pipe diameters upstream of the inlet and 5 pipe diameters following the outlet.

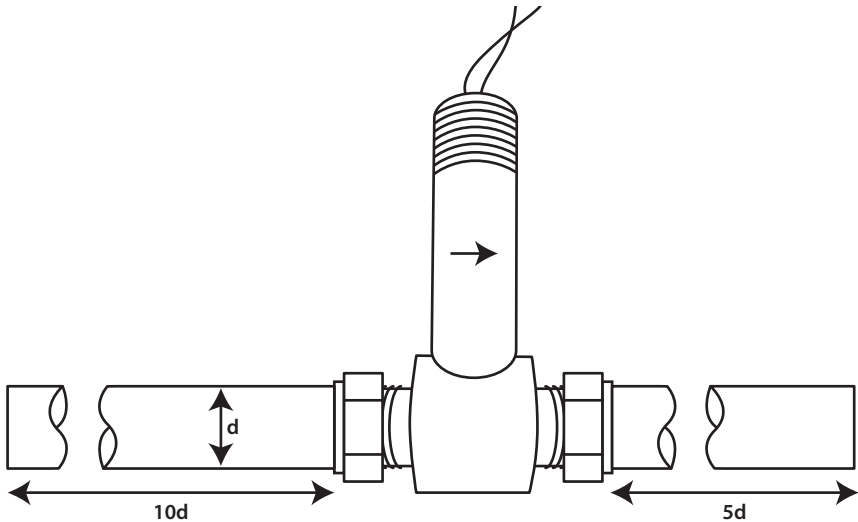

Flowmeter By-Pass

Where possible, such as in a new piping system, it is advisable to include a valved by-pass around the Flowmeter. However, the by-pass connections should not be placed within the recommended straight metering run.

Line Purge

In a newly installed piping system (or one in which fittings have been disturbed) the line should be flushed thoroughly prior to installing the Flowmeter, to minimise possible damage from foreign materials.

Meter Protection

In Line Strainers (Filters) are recommended for meter protection.

The degree of filtration required depends on the size of the Flowmeter.

The following Table is a guide to assist in the choice of filtration.

Model	Recommended Mesh Size
Gz 13	200 microns (0.2 mm)
Gz 16	200 microns (0.2 mm)
Gz 19	200 microns (0.2 mm)
Gz 25	300 microns (0.3 mm)
Gz 40	300 microns (0.3 mm)
Gz 50	300 microns (0.3 mm)
Gz 80	500 microns (0.5 mm)
Gz 100	500 microns (0.5 mm)

Electrical

The voltage output (A.C. sinewave) generated from the Gz Flowmeter varies from a minimum of 10 mV at the lowest flow on the Gz 13 up to 1 V peak to peak for larger Flowmeters at maximum flow.

A twin core screened signal cable should be used for connection to the Pick Up coil.

Transmission distances up to 50 metres can be achieved without the need for amplification.

Atex Pick Up coils can be fitted for Intrinsically Safe applications.

Pick Up Testing

Testing the Pick Up coil consists of measuring the resistance with an Ohm Meter. The resistance measured between the two wires from the Pick Up coil should be approximately 1700 Ohms.

Maintenance

Once installed, the Gz Flowmeter will require no regular running maintenance apart from a periodic check on the Pick Up coil.

It is recommended that the Flowmeter should be removed from the line periodically and inspected for the presence of dirt or foreign bodies in the internal parts.

Board Connections

The Gz Flowmeter is usually supplied with any of the 101 Range of Electronics, however it can be supplied with just a Signal Conditioning Board such as an Amplifier, Scaler or 4 – 20 mA Board.

Amplifier Board Connections

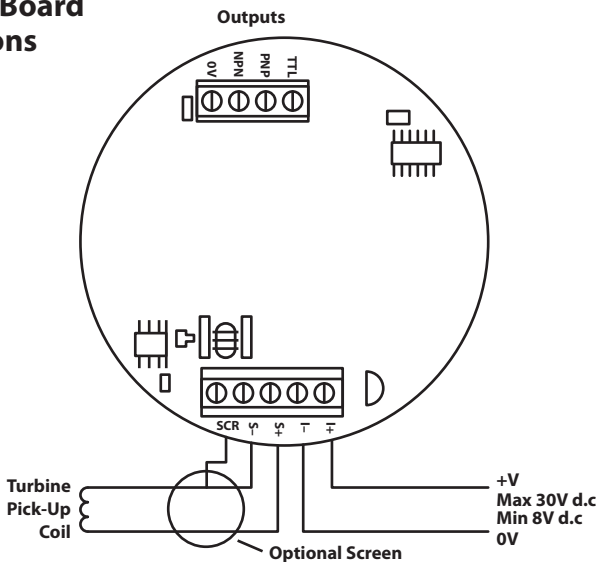

Scaler Board Connections

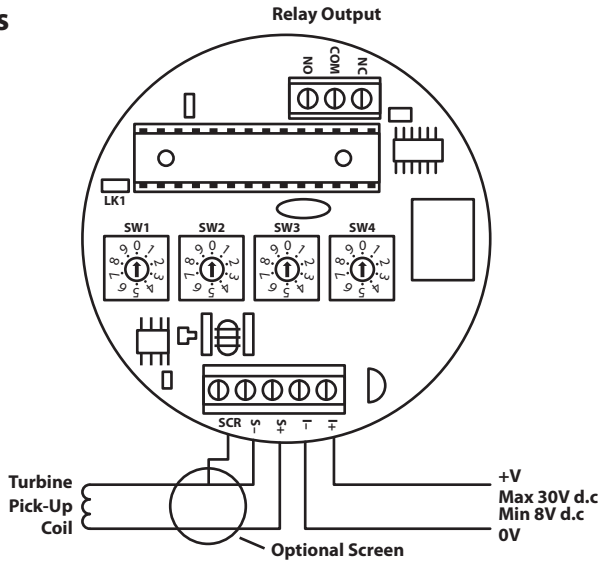

4 – 20 mA Board Connections

