



## SADDLE FOR LARGE PIPE SIZES

The AQUASONIC meter takes our highly accurate Ultrasonic insert and adds our very popular Q9 Display. This meter provides an accurate reading of water flow rate and accumulated total. It is designed to support commercial and industrial applications. Our AQUASONIC is available in 4 saddle line sizes, 6, 8, 10, 12in.

### FEATURES / BENEFITS

- Low-cost, effective and easy installation
- No moving mechanical parts (low-maintenance)
- Pin protection, four digit user selectable
- 2 Totals (Batch Total and Accumulative Total); Rate of Flow
- Diagnostic Meter show % of battery life only on battery powered AQUASONIC (battery powered version only)
- High accuracy:  $\pm 2.0\%$  of reading (compared to full scale accuracy)
- Provides extended leak detection down to 0.1 fps (0.03 m/s)
- Patented design
- Many field configurable options for ease of operation

### SPECIFICATIONS

Saddle Housing	Aluminum
Connection Type	Saddle
Saddle sizes Available	6 in, 8 in, 10 in, 12 in
Insert Wetted Materials:	<b>Body:</b> PPS (Ryton R-4)
	<b>Sensor:</b> PEI (Ultem 1000)
	<b>O-Ring:</b> EPDM
<b>Temperature Rating:</b>	
Operating:	32° F to 140° F (0° C to 60° C)
Storage:	-20° F to +160° F (-29° C to +71° C)
Flow Range:	0.1 to 15 fps (0.03 to 4.6 m/s)
Accuracy:	Typically $\pm 2\%$ of reading
Operating Pressure:	150 psi @ 73° F (10 bar @ 23° C) 100 psi @ 140° F (7 bar @ 60° C)
Transducer Power:	External Power - (4-20mA / Scalable Pulse Output Versions) Supply Voltage: 7.5V (dc) min. to 36V (dc) max, OR Battery Power - Lithium C
Output Frequency:	0 to 100 Hz (4-20mA / Scalable Pulse Output Versions)
Output Pulse Width:	Scaled Pulse configuration options: Limited to max of 50% duty cycle, User selectable pulse widths of 10ms, 25ms, 50ms, 75ms, & 100ms (4-20mA / Scalable Pulse Output versions)
Electronic Options	Battery-Powered (2-Year Life) or External Power (4-20mA / Scalable Pulse Output)

### INSERT DESCRIPTION

Designed for above and below grade applications, such as irrigation, municipal and underground monitoring where the flow rates are between 0.1 to 15 fps (0.03 to 4.6 m/s) and temperatures are below 140° F (60° C). AQUASONIC can be configured in 4-20mA / Scalable Pulse Output, OR battery powered, and in 4 saddle options.

### APPLICATIONS

- Agriculture Irrigation
- Turf / Landscape Irrigation Systems
- Micro Irrigation Systems
- Groundwater Monitoring
- Sub-Metering Applications:
  - » High Rise Tenant Buildings
  - » Apartment Complex
  - » Universities
  - » Commercial Businesses
  - » Processing Facilities

### APPROVALS

IP67

CE



Representation of contents

## SADDLE ONLY SELECTION CHART

Description	Pipe Outside Diameter (in.)	Clamp Outside Diameter (in.)	Clamp Circumference (in.)	Operating Flow Range	Maximum Water Pressure**	Meter Material	Gasket Material	Saddle Material	Clamp Material
6 in. Pipe (NPS/IPS)	6.625	6.48 - 7.13	20.36 - 22.40	.1 to 15 ft/sec (9 to 1350 GPM)*	150 PSI @ 73°F (10 bar @ 23°C)	N/A	Silicone	Aluminum	Stainless Steel
8 in. Pipe (NPS/IPS)	8.625	8.39 - 9.04	25.36 - 28.40	.1 to 15 ft/sec (15 to 2300 GPM)*	150 PSI @ 73°F (10 bar @ 23°C)	N/A	Silicone	Aluminum	Stainless Steel
10 in. Pipe (NPS/IPS)	10.750	10.48 - 11.13	32.9 - 34.97	.1 to 15 ft/sec (24 to 3650 GPM)*	150 PSI @ 73°F (10 bar @ 23°C)	N/A	Silicone	Aluminum	Stainless Steel
12 in. Pipe (NPS/IPS)	12.750	12.46 - 13.11	39.14 - 41.19	.1 to 15 ft/sec (35 to 5300 GPM)*	150 PSI @ 73°F (10 bar @ 23°C)	N/A	Silicone	Aluminum	Stainless Steel
6 in. Tube	6.000	5.91 - 6.56	18.57 - 20.61	.1 to 15 ft/sec (8 to 1230 GPM)*	150 PSI @ 73°F (10 bar @ 23°C)	N/A	Silicone	Aluminum	Stainless Steel
8 in. Tube	8.000	7.79 - 8.44	24.47 - 26.52	.1 to 15 ft/sec (15 to 2200 GPM)*	150 PSI @ 73°F (10 bar @ 23°C)	N/A	Silicone	Aluminum	Stainless Steel
10 in. Tube	10.000	9.73 - 10.38	30.57 - 32.61	.1 to 15 ft/sec (23 to 3500 GPM)*	150 PSI @ 73°F (10 bar @ 23°C)	N/A	Silicone	Aluminum	Stainless Steel
12 in. Tube	12.000	11.72 - 12.37	36.82 - 38.86	.1 to 15 ft/sec (34 to 5100 GPM)*	150 PSI @ 73°F (10 bar @ 23°C)	N/A	Silicone	Aluminum	Stainless Steel
6 in. PIP	6.140	5.91 - 6.56	18.57 - 20.61	.1 to 15 ft/sec (8 to 1230 GPM)*	150 PSI @ 73°F (10 bar @ 23°C)	N/A	Silicone	Aluminum	Stainless Steel
8 in. PIP	8.160	7.79 - 8.44	24.47 - 26.52	.1 to 15 ft/sec (15 to 2200 GPM)*	150 PSI @ 73°F (10 bar @ 23°C)	N/A	Silicone	Aluminum	Stainless Steel
10 in. PIP	10.200	9.73 - 10.38	30.57 - 32.61	.1 to 15 ft/sec (23 to 3500 GPM)*	150 PSI @ 73°F (10 bar @ 23°C)	N/A	Silicone	Aluminum	Stainless Steel
12 in. PIP	12.240	11.72 - 12.37	36.82 - 38.86	.1 to 15 ft/sec (34 to 5100 GPM)*	150 PSI @ 73°F (10 bar @ 23°C)	N/A	Silicone	Aluminum	Stainless Steel

\*Nominal flow rate shown. Actual flow is dependent on pipe schedule (wall thickness).

\*\* Maximum water pressure for larger line sizes would be based on the material of the sensor, adapter, and pipe. Pressure is also derated due to temperature (1.20 psi / °F).

## SADDLE WITH SENSOR SELECTION CHART



Representation of contents

Description	Pipe Outside Diameter (in.)	Operating Flow Range	Maximum Water Pressure**	Meter Material	Gasket Material	Saddle Material	Clamp Material
6 in. Pipe (NPS/IPS)	6.625	.1 to 15 ft/sec (9 to 1350 GPM)*	150 PSI @ 73°F (10 bar @ 23°C)	Ryton	Silicone	Aluminum	Stainless Steel
8 in. Pipe (NPS/IPS)	8.625	.1 to 15 ft/sec (15 to 2300 GPM)*	150 PSI @ 73°F (10 bar @ 23°C)	Ryton	Silicone	Aluminum	Stainless Steel
10 in. Pipe (NPS/IPS)	10.750	.1 to 15 ft/sec (24 to 3650 GPM)*	150 PSI @ 73°F (10 bar @ 23°C)	Ryton	Silicone	Aluminum	Stainless Steel
12 in. Pipe (NPS/IPS)	12.750	.1 to 15 ft/sec (35 to 5300 GPM)*	150 PSI @ 73°F (10 bar @ 23°C)	Ryton	Silicone	Aluminum	Stainless Steel
6 in. Tube	6.000	.1 to 15 ft/sec (8 to 1230 GPM)*	150 PSI @ 73°F (10 bar @ 23°C)	Ryton	Silicone	Aluminum	Stainless Steel
8 in. Tube	8.000	.1 to 15 ft/sec (15 to 2200 GPM)*	150 PSI @ 73°F (10 bar @ 23°C)	Ryton	Silicone	Aluminum	Stainless Steel
10 in. Tube	10.000	.1 to 15 ft/sec (23 to 3500 GPM)*	150 PSI @ 73°F (10 bar @ 23°C)	Ryton	Silicone	Aluminum	Stainless Steel
12 in. Tube	12.000	.1 to 15 ft/sec (34 to 5100 GPM)*	150 PSI @ 73°F (10 bar @ 23°C)	Ryton	Silicone	Aluminum	Stainless Steel
6 in. PIP	6.140	.1 to 15 ft/sec (8 to 1230 GPM)*	150 PSI @ 73°F (10 bar @ 23°C)	Ryton	Silicone	Aluminum	Stainless Steel
8 in. PIP	8.160	.1 to 15 ft/sec (15 to 2200 GPM)*	150 PSI @ 73°F (10 bar @ 23°C)	Ryton	Silicone	Aluminum	Stainless Steel
10 in. PIP	10.200	.1 to 15 ft/sec (23 to 3500 GPM)*	150 PSI @ 73°F (10 bar @ 23°C)	Ryton	Silicone	Aluminum	Stainless Steel
12 in. PIP	12.240	.1 to 15 ft/sec (34 to 5100 GPM)*	150 PSI @ 73°F (10 bar @ 23°C)	Ryton	Silicone	Aluminum	Stainless Steel

\*Nominal flow rate shown. Actual flow is dependent on pipe schedule (wall thickness).

\*\* Maximum water pressure for larger line sizes would be based on the material of the sensor, adapter, and pipe. Pressure is also derated due to temperature (1.20 psi / °F).

# K-FACTORS

K-Value Formula (Turf Controller) = 60 / K-Factor

# DIMENSIONS

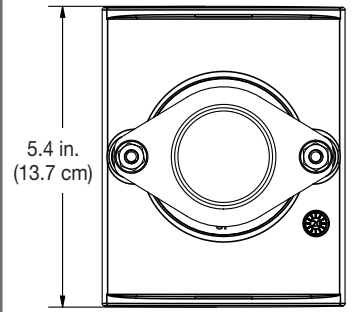
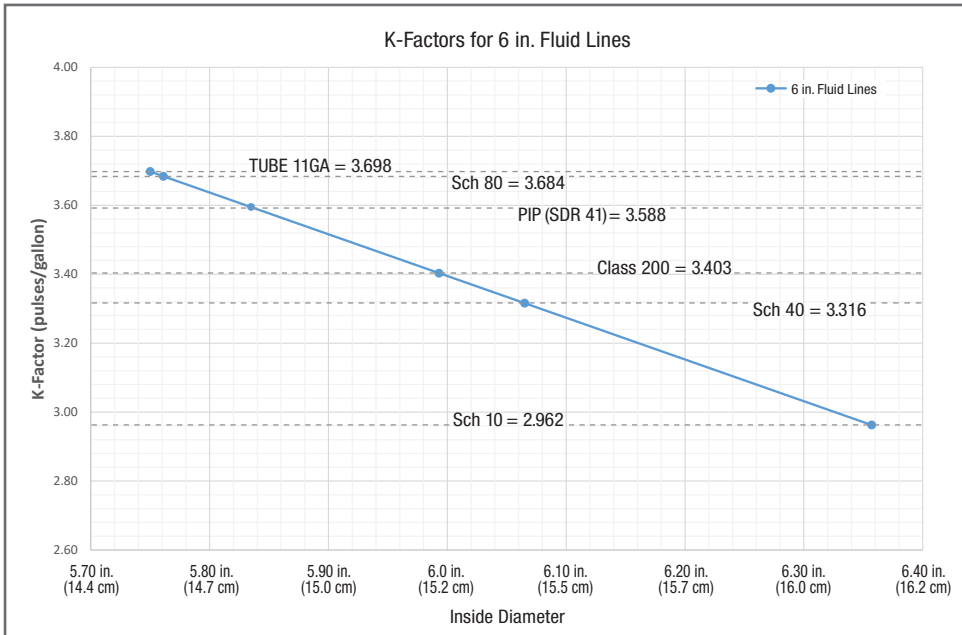

**SADDLE - TOP VIEW**

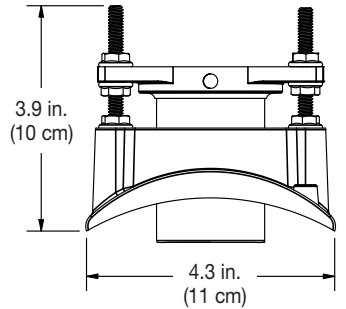

**SADDLE - FRONT VIEW**

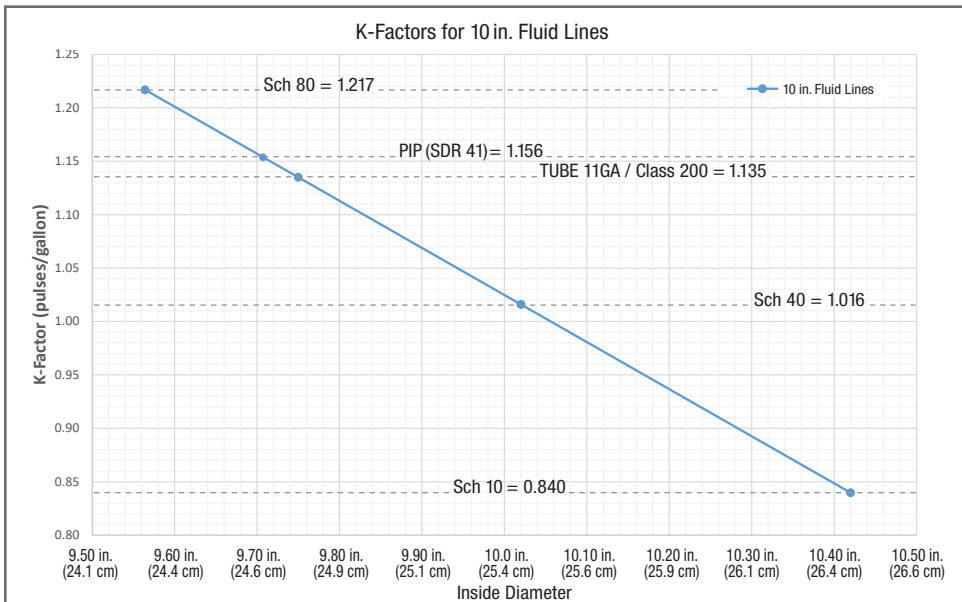
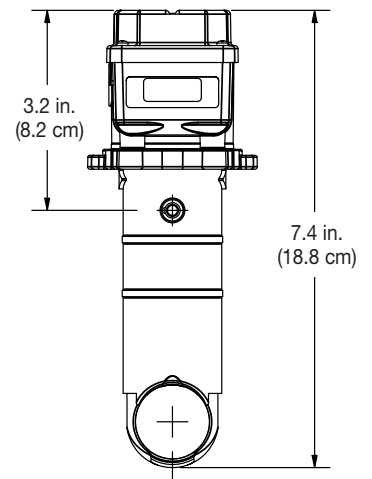
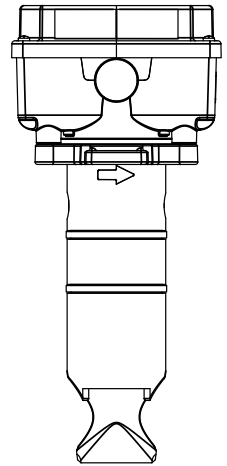
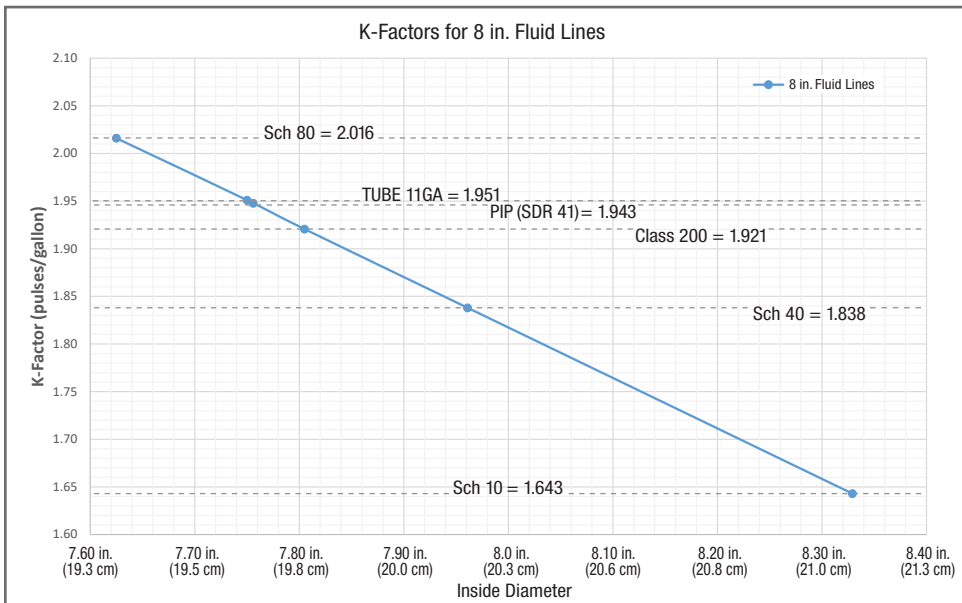

K-FACTORS CONTINUED ON BACK

**AQUASONIC INSERT**

# K-FACTORS CONTINUED

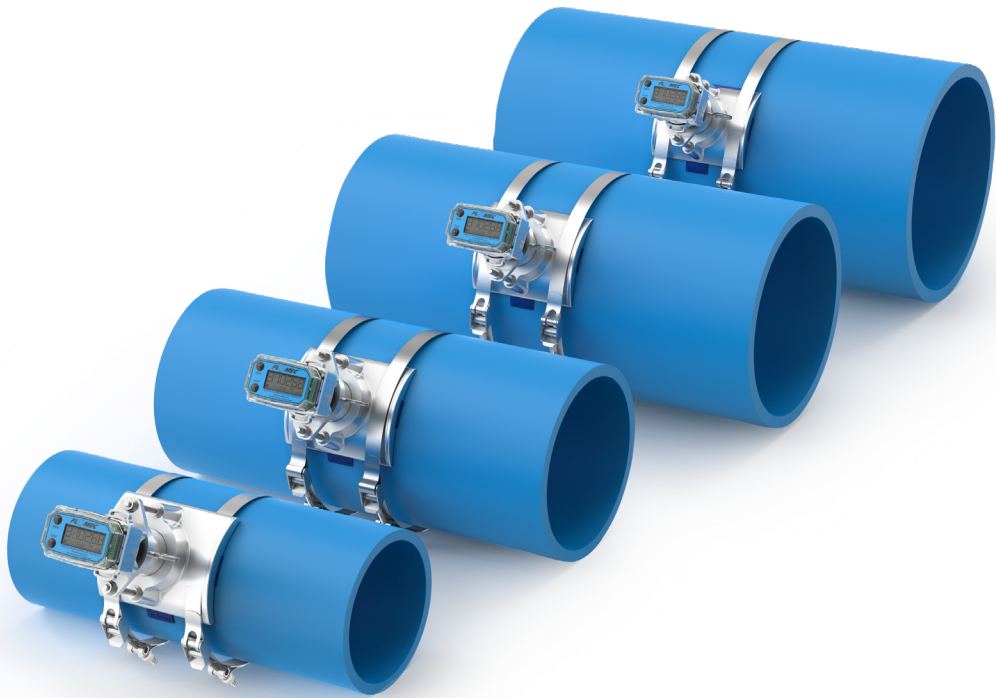
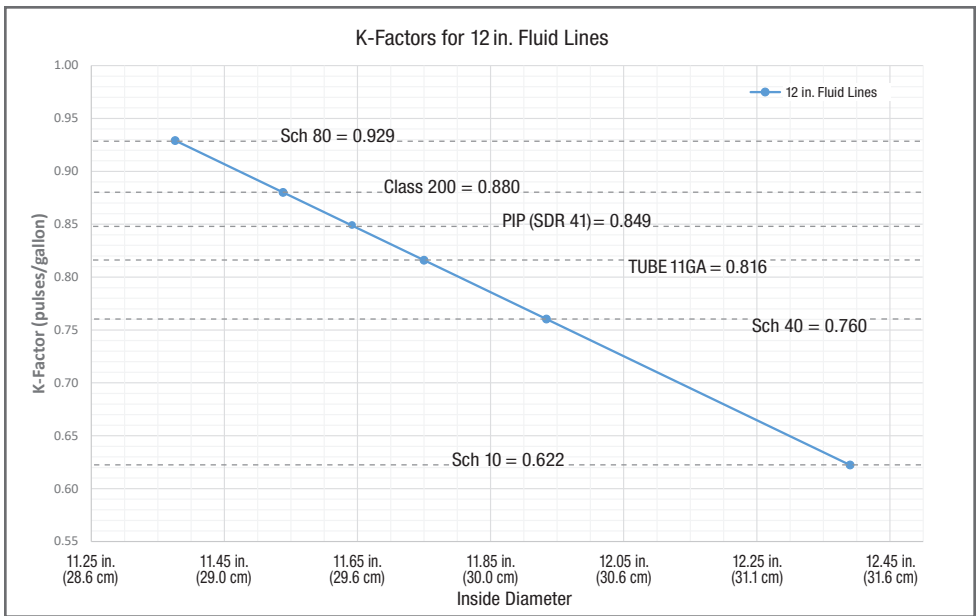

**SADDLE FAMILY LINE-UP** (Shown on pipe. Pipe not included.)