

ULTRAFLO U1000MKII-HM

THE THERMAL, HEAT/ENERGY METERING SOLUTION FROM MICRONICS. SIMPLE, LOW COST, HOT OR CHILLED WATER ENERGY MEASUREMENT FROM OUTSIDE THE PIPE. A SMARTER SOLUTION THAN IN-LINE METERS!

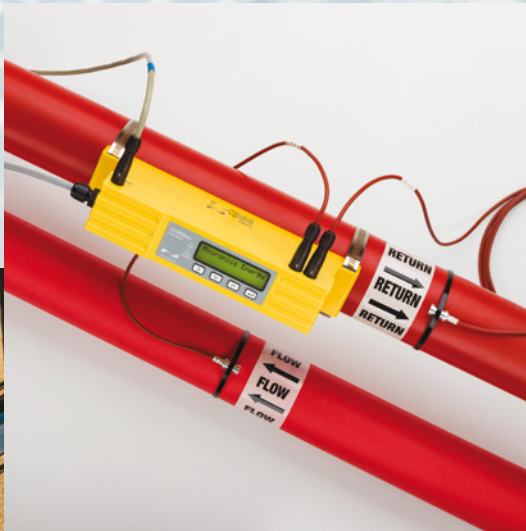

NEW!

Now available in the original pipe-mounted or new wall-mounted, display & keyboard format with extended pipe range.

The U1000MKII-HM is an ultrasonic clamp-on thermal, heat/energy meter that uses ultrasound to measure flow rate and PT100 temperature sensors to measure flow and return temperatures. The U1000MKII-HM displays energy rate and totalised energy with pulse output and communication options, so it can be used as a standalone meter or as an integral part of an aM&T or BEM's system.

A cost effective alternative to traditional in-line meter installation, plus dry servicing, providing minimum downtime and maximum availability!

Compact, rugged and reliable, the U1000MKII-HM has been designed to provide sustained performance in industrial environments.

Simple to install – connect power and enter the pipe inside diameter, adjust the sensors and clamp-on the pipe – no specialist skills or tools required!

Now available with the option of the original pipe-mounted or separate wall-mounted keypad and display plus extended pipe range.



For further information call us on
+49 (0)7025 7381
or email info@stix-flowmeter.de
www.stix-flowmeter.de

STIX
DURCHFLUSSMESSTECHNIK



Industries:

- Building Services
- Energy Management
- Process

Recommended for:

- Hot water
- Chilled water
- Chilled Water with Glycol

Application/use:

- Heat/energy metering in energy management or building services applications for heating or chilled water circuits.

U1000MKII-HM – Pipe Mounted, fixed Ultrasonic Heat/Energy Meter with Modbus and Mbus Communication options

SPECIFICATION

Measurement Technique: Ultrasonic, cross-correlation transit time method for flow measurement.

Turn Down Ratio: 100:1

Heat Meter Standard: The Heat/Energy calculation is designed to comply with EN1434 section 6.

Accuracy: $\pm 3\%$ of flow reading for $>0.3\text{m/s}$ (1 ft/s).

Flow Velocity Range: 0.1m/s – 10m/s (0.3 ft/s – 32 ft/s).

Pipe Range: Available in 2 options. 22mm – 115mm and 125mm – 180mm OD. Note Pipe size is dependent on pipe material and internal diameter.

Pipe Material: Steel, Stainless Steel, Plastic and Copper.

Water Temp Range: 0°C – 85°C (32°F – 185°F).

Temperature sensors: Clamp-on PT100 Class B 4 wire, range 0°C – 85°C (32°F – 185°F), resolution 0.1°C (0.18°F). Minimum delta T is 0.3°C.

Pulse Output: Pulse or Frequency. Pulse for Volume flow and Energy in kWh (BTU). Frequency for flow rate. The pulse output can be configured as a loss of signal or low flow alarm. Opto-isolated MOSFET volt free contact (NO/NC).

Modbus Communication: Optional Modbus RTU slave, RS485 serial link hardware layer. Energy, power, temperature and flow. Modbus connection cable is 1m.

Mbus Communication: Optional.

External Power Supply: 12V – 24V $\pm 10\%$ AC/DC at 7 watts per unit. Optional plug in 12V power supply.

Electronics Enclosure: IP54.

Input/Output Cable: 5m x 6 core for power in and pulse out.

Dimensions: 250mm x 48mm x 90mm (10" x 2" x 4") (electronics + guide rail).



How does it work?

The Ultraflo U1000MKII-HM is a transit time ultrasonic flow meter designed to work with clamp-on transducers, to provide accurate measurement of liquid flowing within a closed pipe, without the need for any mechanical parts to be inserted through the pipe wall or to protrude into the flow system. It takes just a few minutes to install and there is no need to shut down flow or drain the system!

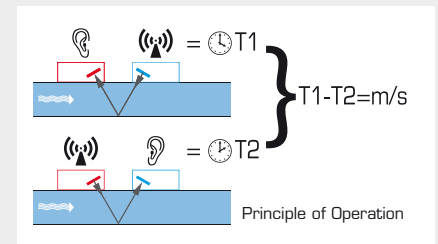

U1000MKII-HM-WM – Clamp-on sensors with separate wall mounted keypad and display

SPECIFICATION

Measurement Technique: Ultrasonic, cross-correlation transit time method for flow measurement.

Turn Down Ratio: 100:1

Heat Meter Standard: The Heat/Energy calculation is designed to comply with EN1434 section 6.

Accuracy: $\pm 1\% - 3\%$ of flow reading for velocity rate $> 0.3\text{m/s}$ ($> 1\text{ft/s}$).

Flow Velocity Range: $0.1\text{m/s} - 10\text{m/s}$ ($0.3\text{ft/s} - 32\text{ft/s}$).

Pipe Range: Available in 2 options. $25\text{mm} - 115\text{mm OD}$ and $125\text{mm} - 225\text{mm OD}$. Note: Pipe size is dependent on pipe material and internal diameter.

Pipe Material: Steel, Stainless Steel, Plastic and Copper.

Water Temp Range: $0^{\circ}\text{C} - 135^{\circ}\text{C}$ ($32^{\circ}\text{F} - 275^{\circ}\text{F}$).

Option: Additional 4-20mA output option for flow only, which can be purchased/used at the same time as modbus/mbus.

Temperature sensors: Clamp-on PT100 Class B 4 wire, range $0^{\circ}\text{C} - 135^{\circ}\text{C}$ ($32^{\circ}\text{F} - 275^{\circ}\text{F}$), resolution 0.1°C (0.18°F). Minimum delta T is 0.3°C .

Pulse Output: Pulse or Frequency. Pulse for Volume flow and Energy in kWh(BTU). Frequency for flow rate. The pulse output can be configured as a loss of signal or low flow alarm. Opto-isolated MOSFET volt free contact (NO/NC).

Modbus Communication: Optional Modbus RTU slave, RS485 serial link hardware layer. Energy, power, temperature and flow.

Mbus Communication: Optional.

External Power Supply: $12\text{V} - 24\text{V} \pm 10\%$ AC/DC at 7 watts per unit. Optional plug in 12V power supply.

Electronics Enclosure: IP68.

Wall Mounted Keypad and Display Dimensions: $215\text{mm} \times 125\text{mm} \times 90\text{mm}$ ($8.46\text{''} \times 4.92\text{''} \times 3.54\text{''}$).

When ultrasound is transmitted between the transducers, its velocity is slightly increased when travelling in the direction of flow, and slightly reduced when travelling against the flow. The resulting transit time difference is directly proportional to the velocity of the flow in the pipe. Having measured the flow velocity and knowing the pipe cross-sectional area, the volumetric flow can be easily calculated.

Hydronic thermal energy, heat or cooling load is calculated from a combination of the flow rate and the flow and return temperature difference or delta T to comply with EN1434 section 6.

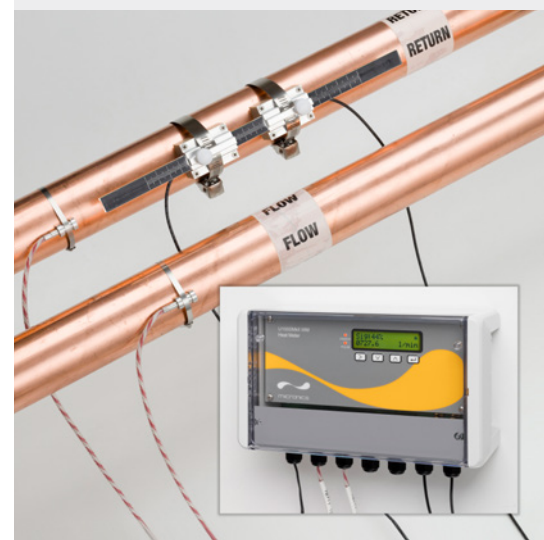

U1000MKII-HM Pipe Mounted Unit

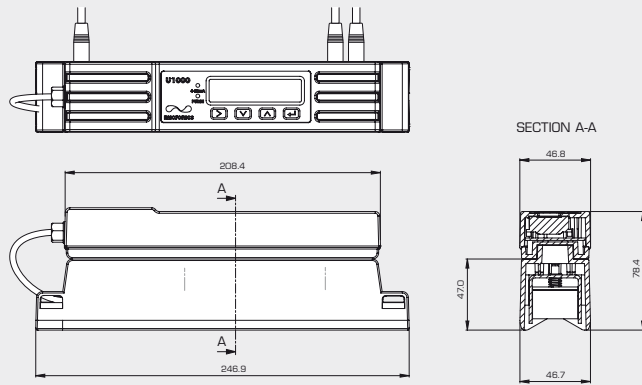

U1000MKII-HM-WM Wall Mount Unit

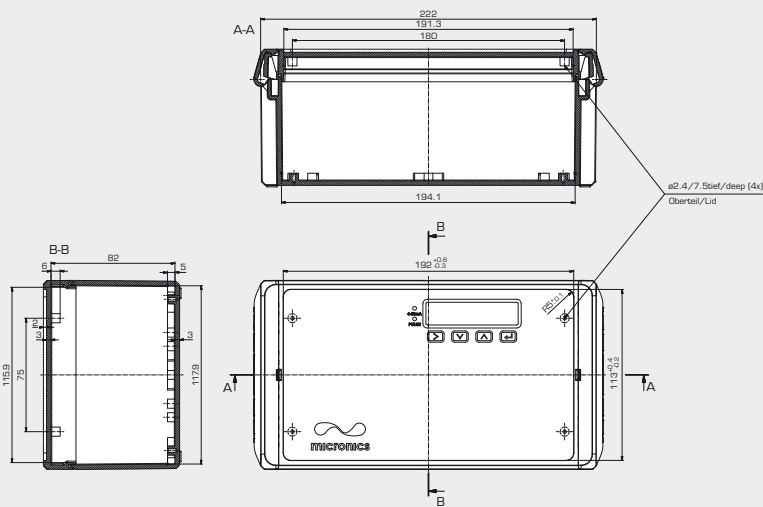

U1000MKII-HM-WM Guide Rail

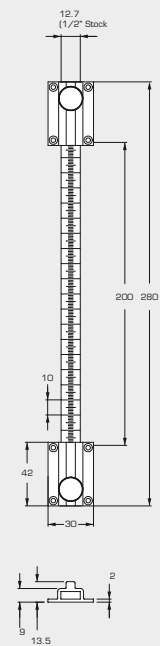

Information subject to change without notice.

The STIX Durchflussmesstechnik GmbH accepts no responsibility or liability if any product has not been installed in accordance with the installation instructions applicable to this product.



STIX Durchflussmesstechnik GmbH
Silcherstr. 16/1, 72664 Kohlberg (Germany)
Telefon: +49 (0)7025 7381 E-Mail: info@stix-flowmeter.de