

**QSI Module  
Installs in Plain Cover Plate  
(QSI2 Shown)**

---

# **QSI ELECTRONICS**

## **FOR USE WITH QSE MAG METERS**

---



*Please save these instructions for future reference. Read carefully before attempting to assemble, install, operate or maintain the product described.*

*Protect yourself and others by observing all safety information. Failure to comply with instructions could result in personal injury and/or property damage.*

*Please refer to back cover for information regarding this product's warranty and other important information.*

**DO NOT RETURN THIS PRODUCT TO THE STORE!**

*Please contact Great Plains Industries, Inc.® before returning any product. If you are missing parts, or experience problems with your installation, contact our Customer Support Department. We will be happy to assist you.*

**Call: 888-996-3837 or 316-686-7361**

**Email: [meters@gplains.com](mailto:meters@gplains.com)**

**SAVE FOR YOUR RECORDS**

**Model #:** \_\_\_\_\_

**Serial #:** \_\_\_\_\_

**Purch. Date:** \_\_\_\_\_

## TABLE OF CONTENTS

<i>Getting Started</i> .....	4
<i>Introduction</i> .....	4
<i>Electrical / Mechanical Specifications</i> .....	5
<i>Installation</i> .....	6
<i>Wiring</i> .....	7
<i>Terminal Connections Chart</i> .....	8
<i>QSI1 Wiring</i> .....	9
<i>QSI2 Wiring</i> .....	10
<i>QSI3 Wiring</i> .....	11
<i>FLOMEC App for Android</i> .....	13
<i>Temperature Probes</i> .....	13
<i>Installation</i> .....	13
<i>Wiring</i> .....	14
<i>Maintenance</i> .....	15
<i>Replacing Battery</i> .....	14
<i>Service</i> .....	17
<i>Returning Parts</i> .....	17
<i>Warranty</i> .....	20

## UNPACKING/INSPECTION



### Inspect

- After unpacking the unit, inspect carefully for any damage that may have occurred during transit. Check for loose, missing or damaged parts. Shipping damage claims must be filed with carrier.
- See General Safety Instructions, and all Cautions, Warnings, and Dangers as shown.



---

## INTRODUCTION

The QSI communications module is a multiple capability electronics package. For the QSE meter, the module is available with the plain cover plate only. The QSI module has three versions (QSI1, QSI2 or QSI3) available; each with its own mix of capabilities to better serve the customer (See Versions below).

- QSI1 is equipped with Bluetooth®, \*\*coil/digital pulse input, pulse output (flow or energy & scalable), RS485 (Modbus® RTU), temperature inputs, BTU calculator.
- QSI2 is equipped with Bluetooth, \*\*coil/digital pulse input, pulse output (flow or energy & scalable), data logger, temperature inputs, BTU calculator.
- QSI3 is equipped with Bluetooth, \*\*coil/digital pulse input, pulse output (flow scalable), data logger, 4-20mA output.

**\*\*NOTE:** *The coil/digital input connections are for use with equipment other than a QSE meter. QSE meters automatically provide coil/digital pulse input via the 10-pin ribbon cable from the AFE PC board.*

This manual contains information and meter wiring diagrams for the three different QSI electronics modules.

### IMPORTANT NOTICE

QSI module electronics are very sensitive to electric noise if operated within 6 inches of some electric motors, relays, transformers or other sources of electronic noise.

If the QSI electronics are used in a manner not specified by the manufacturer, the protection provided by the equipment may be impaired.

### GENERAL INFORMATION

QSI electronics are available integrated into the meter you ordered, and converts the voltage (or pulses) from the meter into usable information.

The QSI module electronics is powered by customer- supplied external power.

### SAFETY

- This product is not approved for use in hazardous locations.
- Be sure O-rings and seals are kept in good repair.
- When applying power, adhere to specifications in this manual.
- Disconnect external power before attaching or detaching input or output wires.

## SPECIFICATIONS

MECHANICAL		ELECTRICAL	
<b>Cover Plate Port Threads</b>	Female 1/2-20 UNF-2B (Compatible with PG7 thread)	Pollution Degree	2
<b>Port Strain Relief</b>	Hubble PG7	Installation Category	1
Grip Range	0.11"-0.26" (2.79 - 6.6mm)	Altitude	2000m Max.
Operation Temperature	+32°F to +140°F (0°C to +60°C)	Indoor use only	
Ambient Air Operation Temp	0°F to +140°F (-18°C to +60°C)	<b>OUTPUTS &amp; COMMUNICATION</b>	
<b>Port Conduit Adapter</b>	GPI PG7 x 1/2 in. NPT Male	<b>QSI Version 1:</b>	
Operation Temperature	+32°F to +140°F (0°C to +60°C)	Bluetooth	
Ambient Air Operation Temperature	0°F to +140°F (-18°C to +60°C)	Coil/Digital Pulse Input**	
<b>Recommended Cable</b>	Belden #9501 (2-Conductor w/Drain Wire, Shielded)	Pulse Output	
<b>POWER SUPPLY</b>		RS485	
Voltage Requirement	Min. 12 VDC (voltages below 12V will result in meter accuracy issues)	Temperature Inputs	
	Max. 36 VDC (higher voltage may damage unit)	BTU Calculator	
Battery Backup (QSI2, QSI3 Only)	Coin cell lithium, 3V (CR2032)	<b>QSI Version 2:</b>	
<b>MAX POWER CONSUMPTION</b>		Bluetooth	
QSE Meter with QSI	170mA 4 watts @ 24VDC 6 watts @ 36VDC	Coil/Digital Pulse Input**	
		Pulse Output	
		Data Logger	
		Temperature Inputs	
		BTU Calculator	
		<b>QSI Version 3:</b>	
		Bluetooth	
		Coil/Digital Pulse Input**	
		Pulse Output	
		Data Logger	
		4-20mA output	

**\*\*NOTE:** The coil/digital input connections are for use with equipment other than a QSE meter. QSE meters automatically provide coil/digital pulse input via the 10-pin ribbon cable from the AFE PC board.

**INSTALLATION**

**CAUTION:** Installation near high electromagnetic fields and high current fields is not recommended and may result in inaccurate readings.

If you ordered your QSI module electronics with a QSE meter, it is installed at the factory. If you ordered your QSI module electronics separately (i.e. repair part), follow the instructions below to install on a QSE meter. If you ordered your QSI module with one of our several types of meter adapter kits, follow the separate instructions enclosed with the kit to install the unit. In every case, please review and thoroughly understand all manuals and installation instructions before proceeding.

To mount your QSI module to a QSE meter:

- Install the cover plate seal.
- Connect the QSI module PC board connector to the AFE module PC board connector inside the meter housing with the ribbon cable. The ribbon cable connectors are polarized and cannot be incorrectly connected (see Figure 1).
- Install the cover plate with screw holes aligned.
- Install the (6) cover plate screws and tighten. Make sure the cover plate seal is fully seated before tightening the screws.

A ribbon cable connects the QSI electronics within the cover plate to the AFE electronics within the meter body and allows 180 degrees of movement in either direction (see Figure 2).

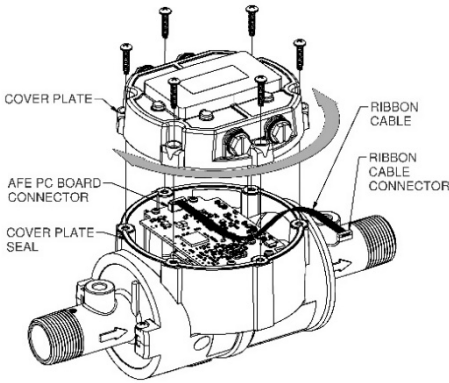

**Figure 1**

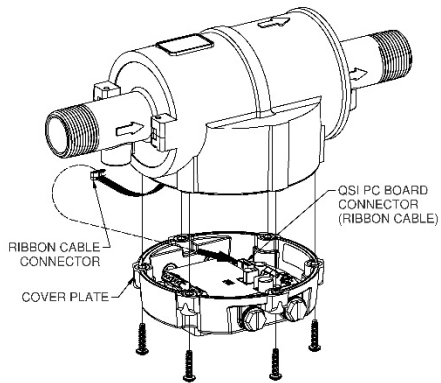

**Figure 2**

## WIRING

The cover plate has four threaded ports, compatible with PG7 threads, for gaining wiring access to the electronics inside the cover plate. The meter is shipped with the ports environmentally sealed with a threaded plug and seal. Remove one or more of these plugs as required to install the supplied port fittings below.

Each meter is supplied with cable gland strain reliefs with O-rings and 1/2 NPT adapters with seals for use in the threaded ports of the meter cover plate. Select the port fittings that fit your process and replace the threaded plugs in the cover plate with the fittings as required. The threaded plugs installed at the factory may be left in any unused cover plate port indefinitely.

It is recommended that a “removable” thread-locker (fluid, stick, tape, spray, etc.) be used when installing the strain reliefs or adapters into the cover plate ports.

### Strain Reliefs

The cable gland strain reliefs will accommodate a cable diameter of 0.11 - 0.26 inches (2.79 - 6.6mm) and provide an environmental seal around the cable when the dome-nut is tightened.

### NPT Adapters

The 1/2 NPT adapter fittings are used for attaching flex conduit to the meter, for those applications that require cable runs to be enclosed in conduit.

**NOTE:** *Cable to be provided by customer to accommodate job requirements. Cable is not included with meter.*

## ISOLATED POWER SUPPLY WIRING

The QSE meter has an internal connection to the conductive fluid through one of the electrodes. The fluid and/or plumbing in most applications should be earth grounded to prevent any static buildup and provide a proper grounding for the system. Therefore, the power supply connection to the QSI should have an earth ground isolated output to prevent ground loop currents. Failure to use an isolated power supply could result in ground faults and could cause accuracy issues caused by stray voltages due to the ground loop currents. Proper grounding is a requirement.

The wire gauge for the power supply cable should be between 16 to 26 AWG to properly fit in the wire termination connector. The external power supply used for supplying power to the QSI should be rated for a minimum of 0.25 Amps.

The power supply polarity is not a requirement for the DC supply as long as the supply is properly earth ground isolated.

**TERMINAL CONNECTIONS CHART**

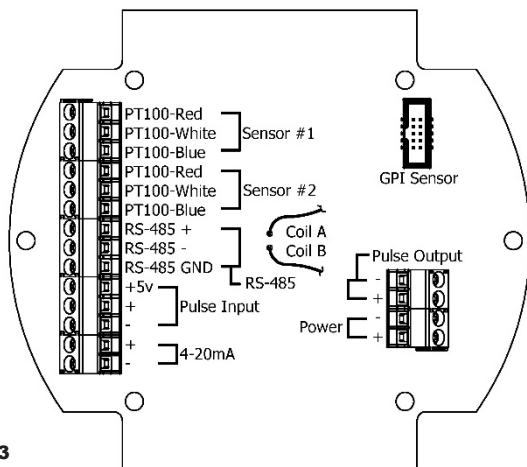

**Figure 3**

TEMP SENSOR	
PT100-Red	Sensor VCC Output
PT100-White	Input High Side
PT100-Blue	Input Return
RS-485 (Galvanically Isolated)	
RS485 (+)	Positive Signal
RS485 (-)	Negative Signal
RS485 GND	Circuit Ground*
PULSE INPUT	
+5V	5VDC output to power external sensor
(+)	Digital Pulse Frequency Input, up to 3kHz
(-)	Digital Pulse Return
4-20mA (Galvanically Isolated)	
(+)	4 to 20mA current loop-current in to transmitter
(-)	4 to 20mA current loop-current out of transmitter*

**\*NOTE:** It is not recommended to connect isolated ground connections together or to board common.

Coil A	Low level sine wave input
Coil B	Low level sine wave input
GPI SENSOR	
Ribbon cable connection to GPI custom sensor designs	
PULSE OUTPUT (Galvanically Isolated)	
(-)	Pulse Output return current*
(+)	Pulse Output frequency output. This is a "current sinking open collector" output ***
POWER INPUT	
(-)	12-36VDC Input A**
(+)	12-36VDC Input B**

**\*\*NOTE:** Polarity of voltage for AC/ DC is not important. However, an earth ground isolated power supply is required to prevent earth ground loop currents and ground fault conditions.

**\*\*\*NOTE:** This output may require an external pull up resistor if interfacing equipment does not include one.



# QSI1 WIRING

## QSI VERSION 1 PC BOARD RS-485 BTU

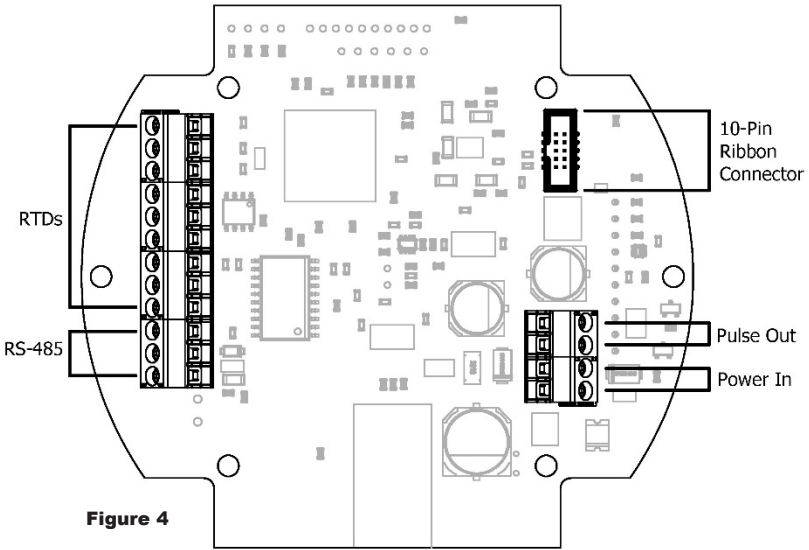

### WIRING DIAGRAM

Inputs: Temperature Sensors, GPI Custom Sensor  
Outputs: RS-485, Pulse Output

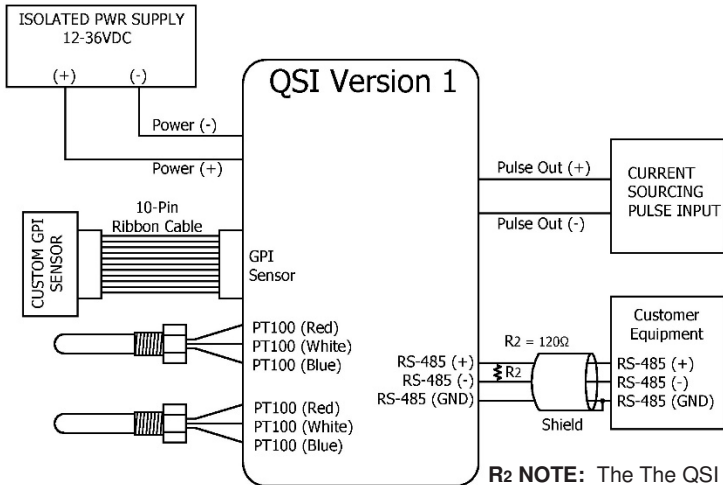

**R2 NOTE:** The QSI does not contain an internal termination resistor. Refer to Customer Equipment documentation for proper installation and resistance value of the external R2 resistor.

**QSI2 WIRING**

QSI VERSION 2 PC BOARD  
Pulse In  
BTU

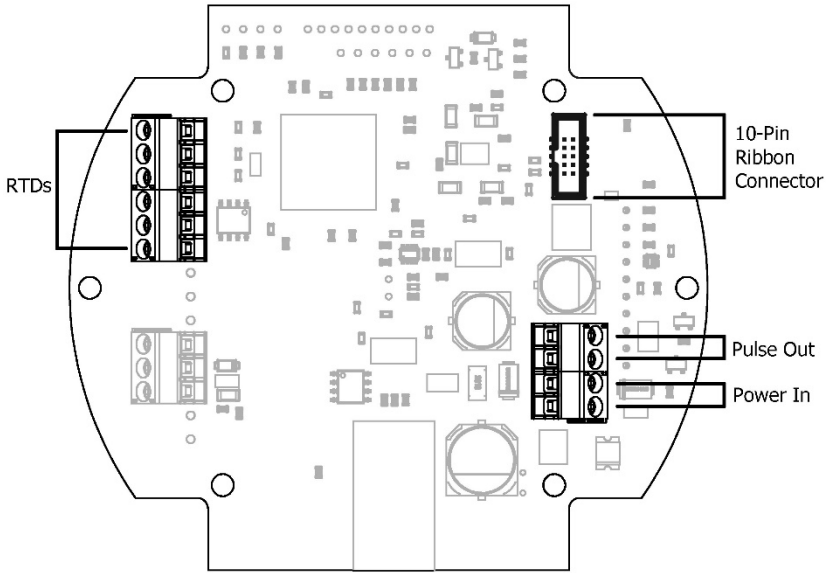

**Figure 6**

**WIRING DIAGRAM**

Inputs: Temperature Sensors, GPI Custom Sensor  
Outputs: Pulse Output

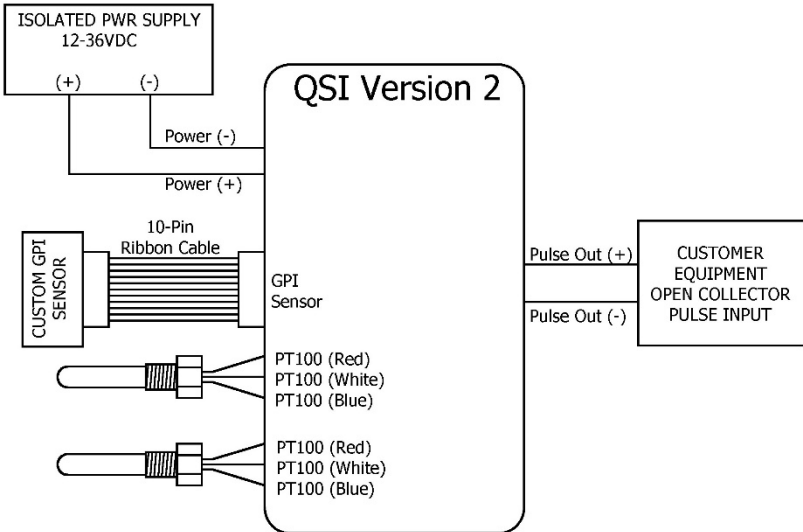

**Figure 7**

**QSI3 WIRING**

QSI VERSION 3 PC BOARD  
4-20mA

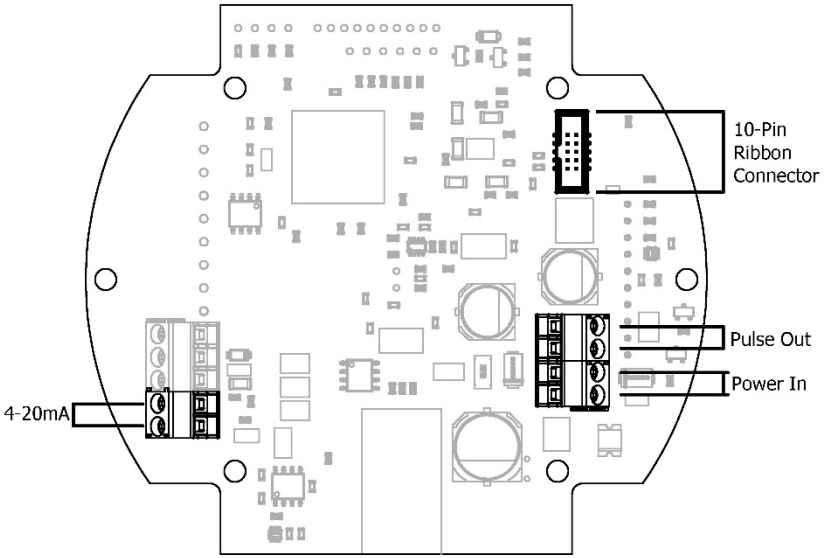

**Figure 8**

**WIRING DIAGRAM**

Inputs: GPI Custom Sensor  
Outputs: 4-20mA, Pulse Output

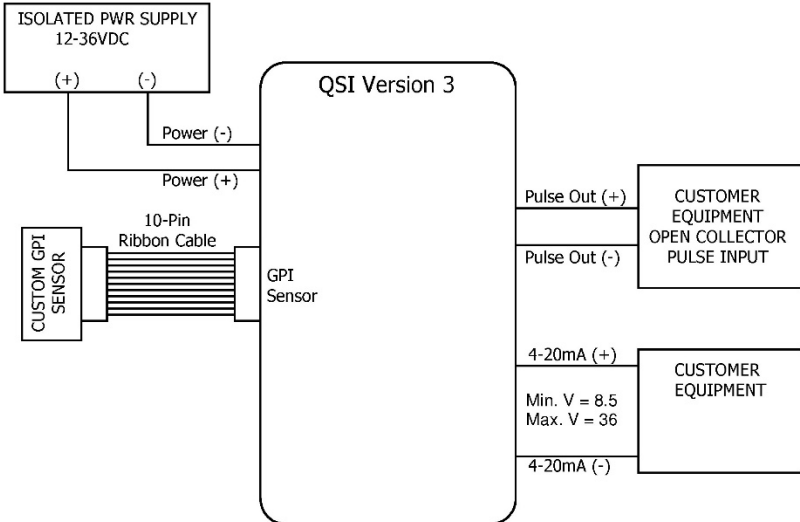

**Figure 9**

WIRING DIAGRAM  
Customer Equipment without Built-in Power Supply  
4-20mA Output with Separate Power Supply

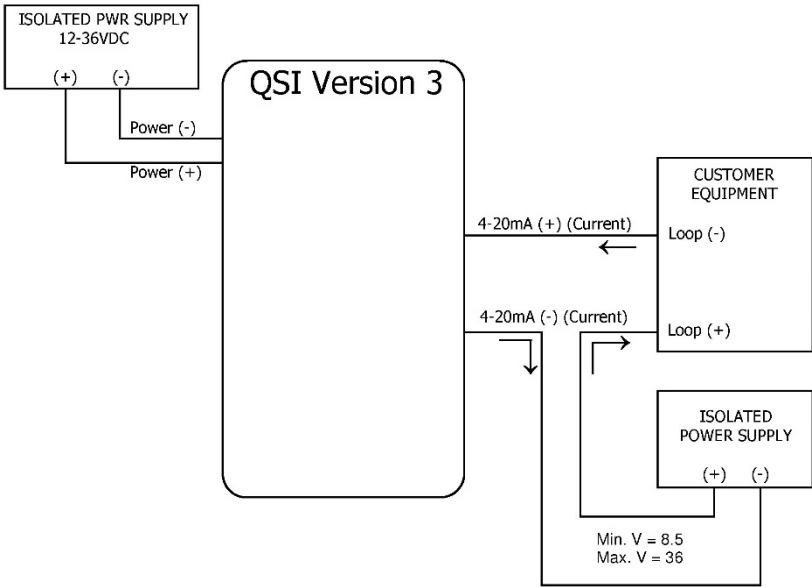

**Figure 10**

## FLOMEC APP FOR ANDROID

To learn how to get started using the FLOMEC App, visit:

[flomecmeters.com/downloads/flomec-app-quickstart.pdf](http://flomecmeters.com/downloads/flomec-app-quickstart.pdf)



## TEMPERATURE PROBES

If you ordered a QSI1 or QSI2 electronic choice with the temperature probe option, the correct length probes with cables are installed near the inlet and outlet ends of the meter. The cables are not connected to the QSI PC board.

If you are installing a temperature probe retrofit kit, you will need to install the probes on the meter.

**CAUTION:** *The temperature probes are not NSF certified. Installation of temperature probes will invalidate NSF approval.*

Enclosed with your meter is a stainless steel pipe plug. It will be used during the set-up process.

## INSTALLATION

**NOTE:** *The meter should be installed in the system return line for accurate BTU calculations.*

Each of the (2) temperature probes has a 10 ft. cable. The threaded body of the probe has 1/8" NPT threads to fit a standard 1/8" NPT port (see Figure 11).

The cable used with the probes has a smaller diameter than the standard strain reliefs (black), installed on the meter at the factory, will allow. Therefore, (2) reduced fit strain reliefs (gray) are included with the probes. For probe cable entry through the ports of the meter cover plate (to wire the system) replace (2) of the (black) strain reliefs in the cover plate with these reduced fit strain reliefs. The entire cable length is used for each probe installation. Both cables require a matched length.

Typically, a temperature probe is installed initially in each of the 1/8" NPT ports of the meter to calculate the differential between the two probes, if any.

The differential is captured and shown in the Android application as "Temp 1" and "Temp 2" and is used in the BTU calculations to ensure an accurate calculation.

For clarity, one probe is considered PT100 #1 and is connected to the meter PC board in that location. It is shown as "Temp 1" in the Android application.

The other probe is then considered PT100 #2 and is connected to the meter PC board in that location. It is shown as "Temp 2" in the Android application.

To perform the differential check, the probe installed in the 1/8" NPT port near the meter **outlet end** should be considered PT100 #1.

The probe installed in the 1/8" NPT port near the meter **inlet end** should be considered PT100 #2.

See Figures 5 and 7 for wiring diagrams.

After wiring the probes to the correct terminal of the PC board, perform the differential check.

**NOTE:** Use thread sealant on the male threads of the probes when installing in either the meter ports or system port.

After performing the differential check, remove the PT100 #2 probe near the inlet end of the meter and install the pipe plug, received with your meter, in the open meter port. Install the removed probe in the system supply line.

**NOTE:** Use thread sealant on the male threads of the pipe plug when installing it in the meter port.

During normal system operation, probe PT100 #1 is installed at the meter outlet end and probe PT100 #2 is installed in the system supply line. Accurate system BTU usage is calculated between the (2) probes.

The excess cable from the PT100 #1 probe (on the meter) to the cover plate may be coiled and secured using plastic quick ties.

### WIRING

See Figures 5 and 7 for wiring diagrams.

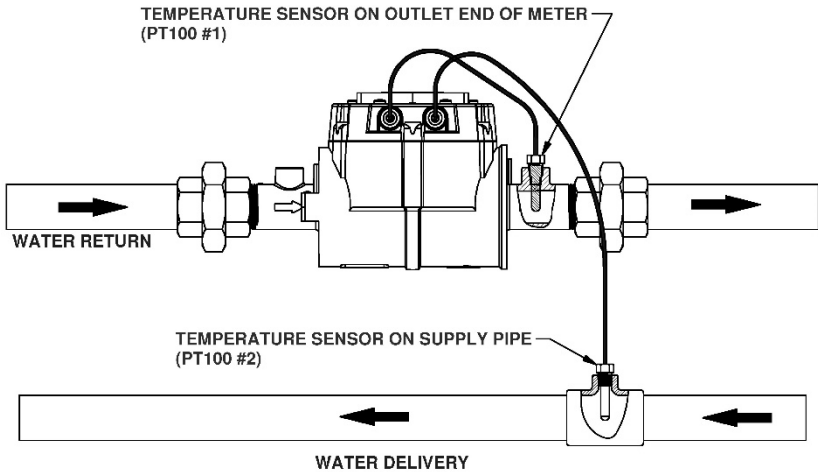

**Figure 11**

## MAINTENANCE

Check cable-entry seals periodically. Tighten and/or apply sealant if needed. This is especially important in environments containing heavy concentrations of dust, oil mist, or other residue.

Check all wiring connections occasionally for oxidation or corrosion. Clean and re-seat if such conditions are noted.

If necessary, check and re-seat any connections that may have been subjected to strain (during rework or construction, for example).

### REPLACING BATTERY

The QSI2 and QSI3 communications module has a 3V lithium coin cell battery installed on the PC board. In case of power failure, the battery functions as power backup to maintain the internal system time. Any QSI2 or QSI3 feature that uses a time reference as part of its functionality will be immediately accurate to the current time when power is restored. **To Replace Battery:**

- DISCONNECT POWER TO METER
- Remove (6) screws retaining the cover plate to the meter body and lift the cover plate free of the meter body (see Figure 12).
- Flip the cover plate over and remove (4) screws retaining the PC board assembly (see Figure 13).
- Remove and replace the coin cell battery (CR2032) on the backside of PC board (see Figure 14).
- Reverse the procedure to reassemble the cover plate to the meter. Make sure the cover plate seal is seated before tightening the (6) cover plate screws.

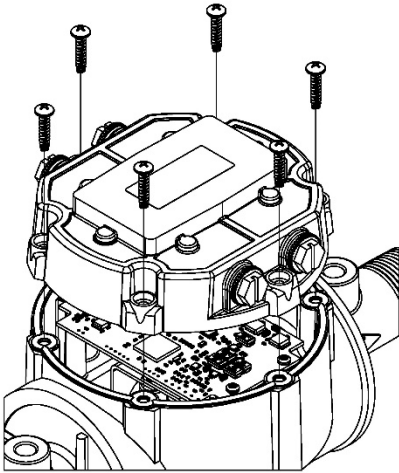

**Figure 12**

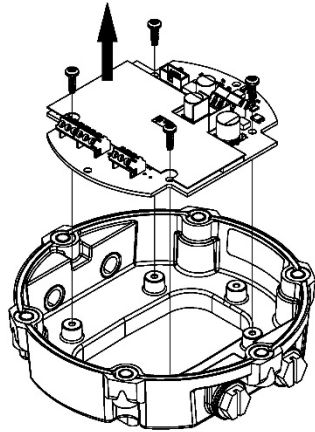

**Figure 13**

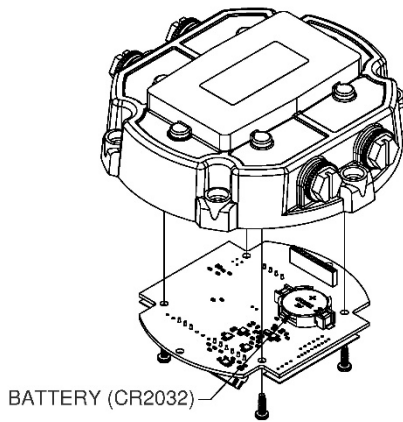

**Figure 14**



## SERVICE

For warranty consideration, contact your local distributor. If you need further assistance, contact the GPI Customer Service Department at:

**1-888-996-3837**

You will need to:

- Provide information from the decal on your meter.
- Receive a Return Authorization number.
- Flush any fluid from the meter before shipping to the factory.

## RETURNING PARTS

Please contact the factory before returning any parts. It may be possible to diagnose the trouble and identify needed parts in a telephone call. GPI can also inform you of any special handling requirements you will need to follow covering the transportation and handling of equipment which has been used to transfer hazardous or flammable liquids.

**CAUTION:** Do not return equipment without specific authority from the GPI Customer Service Department. Due to strict regulations governing transportation, handling, and disposal of hazardous or flammable liquids, GPI will not accept equipment for rework unless it is completely free of liquid residue.



The Waste Electrical and Electronic Equipment (WEEE) directive (2002/96/EC) was approved by the European Parliament and the Council of the European Union in 2003. This symbol indicates that this product contains electrical and electronic equipment that may include batteries, printed circuit boards, liquid

crystal displays or other components that may be subject to local disposal regulations at your location. Please understand those regulations and dispose of this product in a responsible manner.

## RoHS Compliant (2011/65/EU)

This product is in compliance with the RoHS Directive of the European Parliament and of the Council on the Restriction of the Use of Certain Hazardous Substances in Electrical and Electronic Equipment.







**FLOMEC® TWO-YEAR LIMITED WARRANTY**

Great Plains Industries, Inc. 5252 E. 36th Street North, Wichita, KS USA 67220-3205, hereby provides a limited warranty against defects in material and workmanship on all products manufactured by Great Plains Industries, Inc. This product includes a 2-year warranty. Manufacturer’s sole obligation under the foregoing warranties will be limited to either, at Manufacturer’s option, replacing or repairing defective Goods (subject to limitations hereinafter provided) or refunding the purchase price for such Goods theretofore paid by the Buyer, and Buyer’s exclusive remedy for breach of any such warranties will be enforcement of such obligations of Manufacturer. The warranty shall extend to the purchaser of this product and to any person to whom such product is transferred during the warranty period.

The warranty period shall begin on the date of manufacture or on the date of purchase with an original sales receipt. This warranty shall not apply if:

- A. The product has been altered or modified outside the warrantor’s duly appointed representative;
- B. The product has been subjected to neglect, misuse, abuse or damage or has been installed or operated other than in accordance with the manufacturer’s operating instructions.

To make a claim against this warranty, contact the GPI Customer Service Department at:  
**316-686-7361 or 888-996-3837.**

**Or by mail at:**

**Great Plains Industries, Inc.  
5252 E. 36th St. North  
Wichita, KS, USA 67220-3205**

The company shall, notify the customer to either send the product, transportation prepaid, to the company at its office in Wichita, Kansas, or to a duly authorized service center. The company shall perform all obligations imposed on it by the terms of this warranty within 60 days of receipt of the defective product.

GREAT PLAINS INDUSTRIES, INC., EXCLUDES LIABILITY UNDER THIS WARRANTY FOR DIRECT, INDIRECT, INCIDENTAL AND CONSEQUENTIAL DAMAGES INCURRED IN THE USE OR LOSS OF USE OF THE PRODUCT WARRANTED HEREUNDER.

The company herewith expressly disclaims any warranty of merchantability or fitness for any particular purpose other than for which it was designed.

This warranty gives you specific rights and you may also have other rights which vary from U.S. state to U.S. state.

Note: In compliance with MAGNUSON MOSS CONSUMER WARRANTY ACT – Part 702 (governs the resale availability of the warranty terms).



Wichita · Sydney



© 2020 Great Plains Industries, Inc., All Rights Reserved.

Great Plains Industries, Inc. / 888-996-3837 / flomecmeters.com